



Triangle BioSystems
International®



TBSI W128 System Manual Version 3.0

Triangle BioSystems International

2224 Page Rd. Suite 108

Durham, NC 27703

Phone: (919) 361-2663 • Fax: (919) 544-3061

www.trianglebiosystems.com



Triangle BioSystems International is a wholly owned subsidiary of Harvard Bioscience Inc.

Office: (919) 361-2663
Fax: (919) 544-3061
2224 Page Rd. Suite 108
Durham, NC 27703

www.trianglebiosystems.com
sales@trianglebiosystems.com
support@trianglebiosystems.com

Contents

128 CHANNEL WIRELESS NEURAL HEADSTAGE SYSTEM	3
Introduction	3
Features	3
System Configuration	4
System Block Diagram	4
Wireless System Parts List	5
Headstage Transmitter Specifications	6
Headstage Mechanical Overview	7
Wireless Headstage Pinout	7
RF Receiver Specifications	8
RF Receiver Mechanical Overview	8
RF Receiver Signal Interface Options	9
Receiver Signals - Analog Output	9
Receiver Signals– Digital Interface	10
System Setup and Testing	11
Internal and External Batteries	14
Mouse and Rat Saddle Harness	15
Headstage Accessory Options	15
LED Headstage Options	16
Headstage Removal Tool	16
Headstage Electrode Connectors Alignment Tool	16
Wireless Power Headstage Option	16
Electrodes	16
Gain and Phase Response	17
Troubleshooting	17
Application Notes	18
Contact Us	18

128 CHANNEL WIRELESS NEURAL HEADSTAGE SYSTEM



Introduction

The Triangle BioSystems International (TBSI) W128 wireless recording headstage system allows researchers to continuously and simultaneously monitor up to 127 single ended biopotentials as single units, EEG and ECOG. Differential signals such as an EMG recording can easily be accommodated in software. No longer do experiments have to be constrained by tethering a test subject. No longer do experiments have to be constrained by tethering a test subject. The complete system is comprised of a wireless headstage transmitter with integrated battery, RF signal receiver/baseband demodulator, power supply and all required cables. With an effective range of 4 meters, this system provides a wireless connection between the implanted electrodes and the data recording system.

TBSI's custom ASIC technology and proprietary radio design provide high data rates (50 kHz/channel) in a wireless headstage that is both small and light weight (10.0 g). This design also incorporates preamplifier circuitry to create an extremely compact and powerful transmitter.

Features

- Wireless operations across 4 meters
- 127 single ended recording channels
- Headstage transmitter weight: 10.0 grams
- Default Total System voltage gain of 800, other gain offerings available
- Rechargeable battery with 3.5 – 4.2 hours of battery life
- Bandpass filtering per channel at .8 Hz to 7 kHz typical
- 50 kHz per channel sampling rate
- Operates in unlicensed radio band below FCC limits
- Covered or dipped headstage options



Headstage



Receiver with Dual Antennae

System Configuration

The receiver antennas must be clipped to a surface within 4 meters from the animal at all times to achieve optimal signal quality. They should be positioned above the animal's cage. Be careful not to obstruct the line of site path between the animal and the receiver antenna with any material except for glass or plastic.

See the section entitled [System Setup and Testing](#) for more details on proper system assembly and positioning.



Standard TBSI Wireless Recording Setup

System Block Diagram

The wireless neural headstage system consists of a wireless transmitter headstage, an RF receiver and baseband demodulation subsystems as shown below:

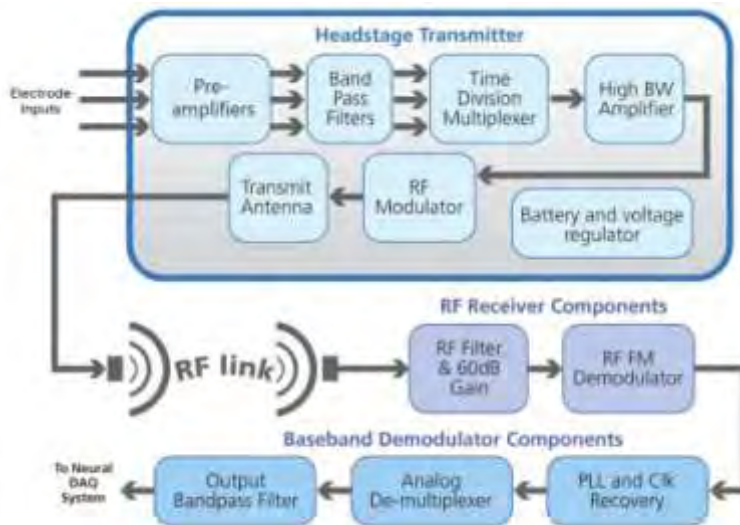

NOTE: These products are not intended for human use.

Wireless System Parts List



Wireless System Parts List		
Item #	Part Number	Description
1	Various	Headstage
2	Various	Wireless Radio Receiver (Analog or Digital)
3	110-0001-00	W-Series Receiver Antenna
4	300-0002-10	Receiver Antenna Extension Cable and Mounting Clamp, 5 ft
5	100-0000-10	Receiver 6 VDC power supply 120 VAC/240 UL and FCC approved
6	100-00001-00	Record or Stim Wireless Headstage Battery Charger, 4.7 V
7	200-0021-10	W32 Signal Input Test Cable, All Channels Combined, Single GND
8	300-0000-00	Magnetic Wand, Headstage On/Off, 12 In
9	202-0001-10	Male DB 37 Connector and housing
10	200-0011-00	4 foot earth GND cable for receiver banana jack (Not Pictured)

Headstage Transmitter Specifications

PARAMETER	MIN	TYP	MAX	UNITS	NOTES
Power					
Current Draw	26 ^A		48 ^B	mAh	A. Standard Version B. High Power Version
Battery		60		mAh	
Analog Input Specs					
Input voltage range			4	mVp-p	
Gain Selection	790	800	810		Factory selectable total system gain
Bandwidth	0.8		7000	Hz	-3 dB input signal level BW
Input impedance		6.5 M		Ω	At 1kHz
Input referred noise		8.5		μ Vrms	for 1 Hz – 7 kHz frequency, 35 μ Vp-p
Sampling/Channel		50		kHz	At headstage (max 30 kHz sampling rate/channel at ADC)
Mechanical Specs					
Length		34.3		mm	Edge to Edge (including connectors)
Width		28.7		mm	Edge to Edge
Height		14.2		mm	Edge to Edge
Weight		10.0		g	With connector and dipped package
Input connector					8 Pin Omnetics, .025"
Radio Specs					
	F1	F2	F3		
Center frequency	3.05	3.375	2.7	GHz	With +/- 100 MHz bandwidth
Transmit power	300	300	300	μ W @ 3 M	FCC Sec. 15 109B(a)
Transmit antenna	3.05	3.375	2.725	GHz	Tuned chip antenna with circular diversity
Transmit range	4.0	4.0	4.0	M	With connector and dipped package

Headstage Mechanical Overview



Complete headstage weight is 8.9 grams

Wireless Headstage Pinout

A		B		D		C	
Ch31	●	Ch63	●	Ch127	●	Ch95	●
Ch29	●	Ch61	●	Ch125	●	Ch93	●
Ch27	●	Ch59	●	Ch123	●	Ch91	●
Ch25	●	Ch57	●	Ch121	●	Ch89	●
Ch23	●	Ch55	●	Ch119	●	Ch87	●
Ch21	●	Ch53	●	Ch117	●	Ch85	●
Ch19	●	Ch51	●	Ch115	●	Ch83	●
Ch17	●	Ch49	●	Ch113	●	Ch81	●
Ch15	●	Ch47	●	Ch111	●	Ch79	●
Ch13	●	Ch45	●	Ch109	●	Ch77	●
Ch11	●	Ch43	●	Ch107	●	Ch75	●
Ch9	●	Ch41	●	Ch105	●	Ch73	●
Ch7	●	Ch39	●	Ch103	●	Ch71	●
Ch5	●	Ch37	●	Ch101	●	Ch69	●
Ch3	●	Ch35	●	Ch99	●	Ch67	●
Ch1	●	Ch33	●	NC	●	Ch65	●
ACGND	●	ACGND	●	ACGND	●	ACGND	●
Ch32	●	Ch64	●	Ch126	●	Ch96	●
Ch30	●	Ch62	●	Ch124	●	Ch94	●
Ch28	●	Ch60	●	Ch122	●	Ch92	●
Ch26	●	Ch58	●	Ch120	●	Ch90	●
Ch24	●	Ch56	●	Ch118	●	Ch88	●
Ch22	●	Ch54	●	Ch116	●	Ch86	●
Ch20	●	Ch52	●	Ch114	●	Ch84	●
Ch18	●	Ch50	●	Ch112	●	Ch82	●
Ch16	●	Ch48	●	Ch110	●	Ch80	●
Ch14	●	Ch46	●	Ch108	●	Ch78	●
Ch12	●	Ch44	●	Ch106	●	Ch76	●
Ch10	●	Ch42	●	Ch104	●	Ch74	●
Ch8	●	Ch40	●	Ch102	●	Ch72	●
Ch6	●	Ch38	●	Ch100	●	Ch70	●
Ch4	●	Ch36	●	Ch98	●	Ch68	●
Ch2	●	Ch34	●	Ch97	●	Ch66	●
ACGND	●	ACGND	●	ACGND	●	ACGND	●

RF Receiver Specifications

- Two of the Three available transmission frequencies
 - F1 - 3.05 GHz center transmit frequency with +/-100 MHz FM bandwidth
 - F2 - 3.375 GHz center transmit frequency with +/-100 MHz FM bandwidth
 - F3 - 2.725 GHz center transmit frequency with +/-100 MHz FM bandwidth
- 4.0 M maximum range between headstage transmitter and receiver antennae
- Front-end gain: 60 dB
- Intermediate gain: 10-20 dB
- Input referred noise, typical: 4 μ V RMS
- Input voltage range: +/- 0.5 V
- Analog channel bandwidth: 20 kHz
- DC offset: < 100 μ Vdc
- Phase delay typical: 30 μ sec at 10 kHz
- Signal lock indicator: LED on front panel

RF Receiver Mechanical



- 1 On/Off Switch
- 2 Signal Lock LEDs
Power On LED
- 3 Antenna SMA Connectors
- 4 Analog Output Connectors (DB37)
- 5 GND Connector Option
- 6 Receiver Power Supply Connector
(DC6V @ .8A)

RF Receiver Signal Interface Options

The W32 RF Receiver Base Station is available in many different system configurations to accommodate a wide range of data acquisition system interface requirements. The RF receiver signal is demodulated by a custom digital signal processing system that incorporates a high speed analog to digital converter for demodulating the receiver signal. The demodulated signal is then conditioned via the DSP and converted to an analog signal. The analog signal can be directly output to one or two DB-37 connectors, input to an integrated Analog to Digital Converter (ADC) or both.

Receiver Signals - Analog Output

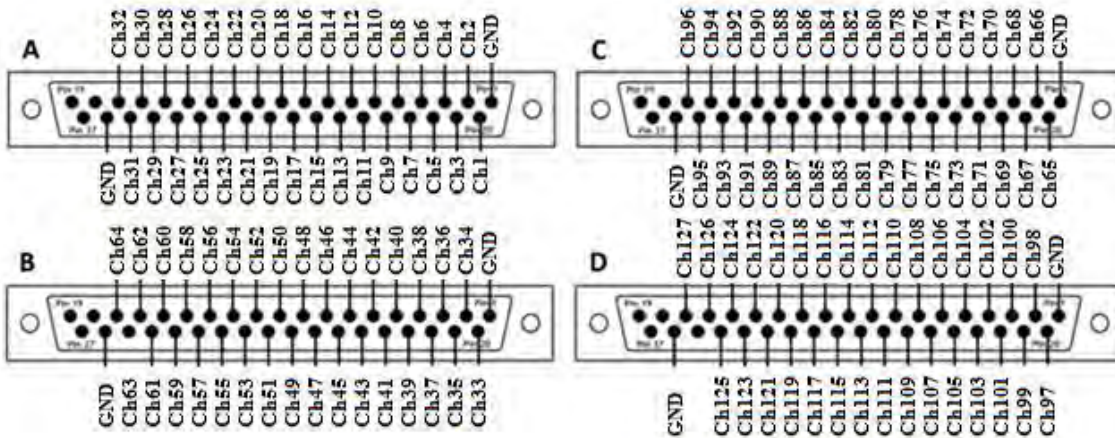

Receiver Signals- Digital Interface

TBSI offers an internal DAQ board option and [NeuroWare™](#) software for the 5ch, 16ch, 32ch and 64ch receivers which can be used for signal data acquisition and analysis. Digital output and event input information is sent to the PC via a USB connection. The total system gain for the digital receiver is 800. The integrated data acquisition card can also be read using DAQ toolkits from MatLab® and Labview®.

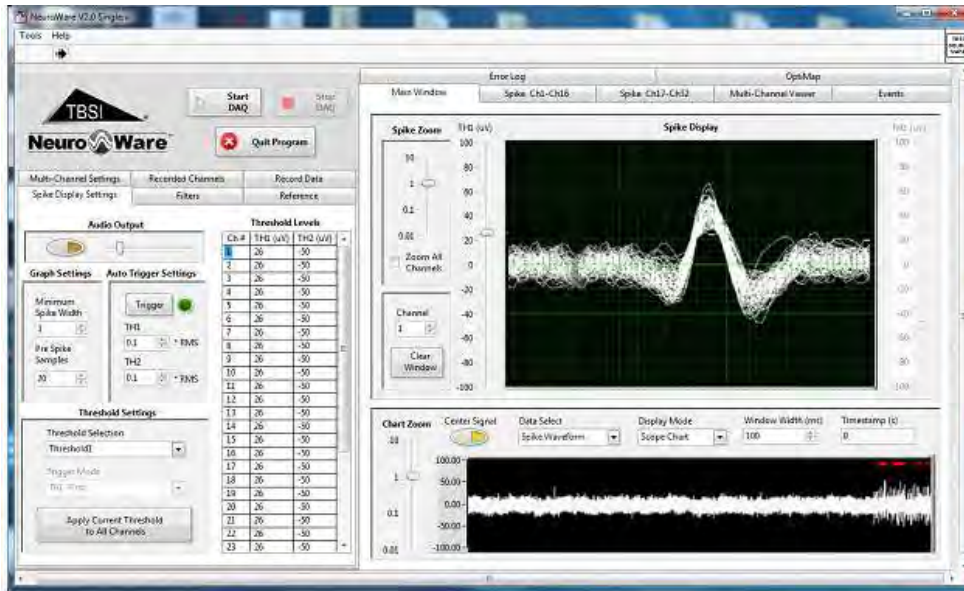

System Setup and Testing

The steps below should be followed when setting up your W32 system to optimize its performance.

1) Charging the Headstage Lithium Ion Battery

The wireless headstage includes an integrated rechargeable battery which should be recharged when not in use. Recharging is accomplished by the following procedure:

- Turn off the headstage transmitter using the magnetic wand (blue light will turn off as indication).
- Connect the battery charging adapter to a wall socket.
- The white charging plug is keyed and mates with the white socket on the side of the headstage. Connect the charging cable to the headstage, making sure that the connection is sound.
- The indicator light on the charging unit is red while charging and green when the connected battery is halfway recharged. A dead battery will become fully charged within approximately one and a half hours after the light has turned green.



2) Correctly position the receiver near the animal's cage:

It is critical for transmission performance to correctly position the receiver next to or inside the animal's cage. First, screw the antennas onto both antenna clamps gold input SMA connectors located on the side of each clamp. Attach the SMA connector of the antenna cable to the mating SMA connector on the receiver box. For best results, position the antennae at 45 degree angles with respect to the cage area and aim them towards center of the cage.



3) Connect power supply to receiver

Plug the DC end of the power supply cable into the back of receiver and the other end into an AC outlet. The recording system is powered by an AC line adapter transformer/regulator. This power unit connects to a 100-240 VAC, at 47-63 Hz and is rated at 6 VDC at 2.5 A power source and is UL approved. Use a suitable International adapter to mate the standard US plug to your AC outlet.



4) Connect signal cable to receiver analog output DB37 connector

If your system was configured for analog system output, connect a suitable analog output cable to the DB37 receiver connector. Five signal wires and a ground wire can be added to the DB37 mating connector to check for signal output. The lengths of the wires are not critical. The analog output channel positions are described in the section entitled [Receiver Signal Interface – Analog Output](#).

If your receiver has an integrated DAQ, plug the USB cord into the receiver and PC and follow the instructions provided in the [Neuroware Manual](#) or your data acquisition software for signal acquisition and viewing.

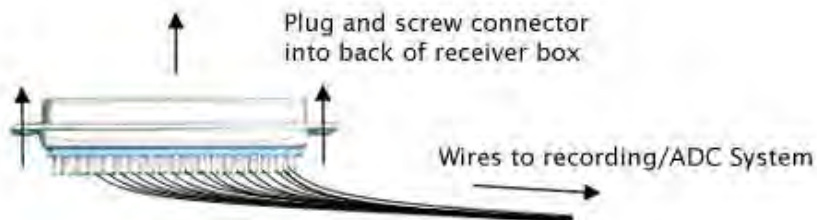

5) Turn on Receiver

Flip the on/off button of the receiver to control power to the receiver.

6) Signal Lock LED and measure analog output signals

Once the receiver and headstage (see #7 below) have both been switched on, the “**Signal Lock**” LED on the receiver front panel should light up. After confirming the signal lock integrity, you can view the analog signals (output from the DB37 connector on the back of the receiver) with an oscilloscope. Please note the default system gain is 800, therefore you can expect the analog output values to be about 800 Vp-p of the signal from the function generator.

7) Test headstage signal transmission with the W128 Signal Input Test Cable



- Line up the two guide pins on the headstage with the guide pin holes on the test cable. Make sure that the labels on the connectors face the same direction.
- W128 Signal Input Test Cable(200-0021-10) supplied with receiver
- Signal leads – connect to positive side of function generator
- GND Leads – connected to signal Ground side of function generator: - Input a 1 kHz sine wave signal at maximum 4 mVp-p amplitude. The function generator signal output voltage cannot exceed 4 mVp-p, otherwise the headstage input voltage range will saturate.
- Once the test cable has been attached, use the magnetic wand to turn on the headstage. Briefly hold the black tip of the wand next to the top of the headstage until you see the blue “power on” LED. The headstage will transmit data continuously while this LED is on.

8) Inductive Power Headstage and Charging











If the wireless power charging accessory is used, please follow the steps below for charging the headstage.

- Plug in the Inductive charger power supply. Turn the transmitter on using the power switch on the face of the Inductive power base station.
- Turn on the headstage charge coil using the RED end of the magnet wand. “On” will be indicated by a RED LED.
- With the RED LED lit place the headstage in the Inductive transmit field. A GREEN LED will indicate that the battery is being charged. Charge the headstage for 2 hours to fully charge the headstage battery.
- Use the BLUE end of the magnet wand to turn on the TBSI headstage for recordings. The headstage radio ON is indicated by a BLUE LED.

Internal and External Batteries

The TBSI W16 recording headstage is typically configured with a 60 mAh internal battery. The W32 headstage can also be built with an internal 75 mAh internal battery for increased recording capacity. Alternatively the headstage can be configured for use with an external battery. Several different external batteries are available and are listed in the table below. For rodent applications we offer both a mouse and a rat saddle harness with Velcro pad (See the section entitled [Mouse and Rat Saddle Harness](#) below).

Removing the internal battery will reduce the weight and size of the headstage by an amount comparable to the battery specifications as listed in the following table.

TBSI W-Series External Batteries				
				
Capacity	10 mAh	40 mAh	60 mAh	75 mAh
Weight	0.6 g	1.5 g	1.6 g	4.4 g
Size (L xW x H)	12 x 11 x 3 mm	15.3 x 15 x 6 mm	16.2 x 11 x 6 mm	25.2 x 20 x 4.7 mm
Hours (STD/HPT)¹	(0.8/0.4)	(3.1/1.7)	(4.6/2.5)	(5.8/3.1)
Product Number	109-0001-10	109-0002-10	109-0003-10	109-0004-10
				
Capacity	180 mAh	200 mAh	220 mAh	500 mAh
Weight	5.3 g	4.7 g	5.3 g	11.6 g
Size (L xW x H)	28 x 20 x 4.5 mm	34 x 11.6 x 6.2 mm	30 x 25 x 3.8 mm	40 x 29.8 x 4.6 mm
Hours (STD/HPT)¹	(13.9/7.5)	(15.4/8.3)	(16.9/9.2)	(38.5/20.8)
Product Number	109-0005-10	109-0012-10	109-0013-10	109-0025-10

1. Hours of Operation: STD - Standard transmission power headstage; HPT – High power transmission headstage



100-0001-04
External Battery Charger 4.7 V



External Battery and Headstage



International AC Power Adapters are included each systems. A complete set

2 prong male connector

Connector

of adapters can also be purchased separately (Part #: AC5).

Mouse and Rat Saddle Harness

Saddle harnesses can be used for external battery options:



Mouse Saddle Harness
004-0001-10



Rat Saddle Harness
004-0001-20



Rat Saddle Harness with Mounted
500 mAh External Battery

Headstage Accessory Options

Three biosensor options are available as add-ons for any wireless headstage. These accessories replace channels typically used for neural recording on the headstage. Installation of any of these features increases the headstage length by 0.4 inches, its height by 0.2 inches, and its weight by 0.4 grams. The features can be installed individually or together in any combination. See the [TBSI Biosensors Brochure](#) for more information. Due to the fact that sensor options require 1 or 3 data channels each, these may not be practical for use with the W16 headstage; consider a W16 or higher headstage.

Accelerometer

This add-on will monitor x, y, and z acceleration vectors and output the information via three analog signal channels. The animal head position and velocity can later be calculated with software such as Matlab.

Ultrasonic Microphone

This single ultrasonic microphone enables recording of audio frequencies between 1 kHz and 25 kHz (W5 and W32 Headstages) or 1-40 kHz (W16 and W64 Headstages) and uses one recording channel.

Temperature Sensor

A Thermistor based temperature sensor option is available. Many sensor sizes are available including very small ones that can be implanted within or near the brain. The sensor must be attached to a mating connector and externalized to the head of the animal much like traditional recording electrodes. Sensors are customized to your particular research needs.



LED Headstage Options

Red, blue or green permanently affixed LEDs or socket mounted LEDs are available for the W128 headstage. The LEDs are placed facing upward on top of the headstage and are suitable for use with most video tracking software applications. The LEDs will turn on when the headstage is turned on. Installation of LEDs on the headstage may reduce battery life by as much as 15%.



Headstage Removal Tool

This tool is used to remove a headstage from the rat or mouse's head quickly and efficiently, its part number is 300-0006-10



Headstage Electrode Connectors Alignment Tool

2xA9409 Female, 36 pin, 4 post, 25mil Omnetics Connector, Part Number: 010-0059-12



Wireless Power Headstage Option

This unique wireless power system is designed to keep a wireless headstage internal battery perpetually charged, thereby enabling indefinitely and uninterrupted device operation. There are 4 major components including the power amplifier transmitter, transmitter coil around the animal's cage, power supply and headstage pickup coil with harvester. Since the transmitter coil is carefully tuned and sized for the animal cage dimensions, it is important to note that the wireless power transmit coil must be placed carefully on a bench top or cage rack without nearby metal and at least 15 inches from other TBSI wireless powering systems.



Electrodes

Many electrode manufactures offer electrode arrays compatible with TBSI wireless headstages. [Cambridge Neurotech](#) offers an extensive line of silicone probes suitable for chronic signal recordings from our wireless headstages. Compatible electrode arrays are also available from Microprobes, Inc., NeuroNexus and others electrode providers.

Gain and Phase Response

Please refer to the section of this document entitled "[Headstage Transmitter Specifications](#)" for numerical data on bandwidth and input referred noise.

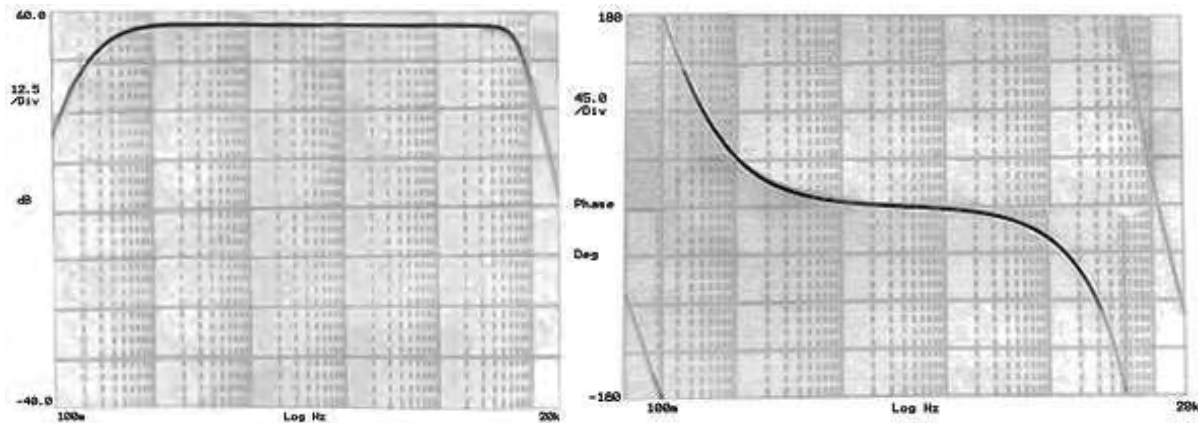

Troubleshooting

Problem: No neural signals are visible on any of the analog outputs at the DB37 connector.

Suggestion: Verify the AC power connection is in place and the green "Power" LED is illuminated on the front of the RF receiver box. Also, verify that the yellow "Signal Lock" light is illuminated, which confirms that the receiver is receiving the signal transmitted from the headstage.

Problem: Visible neural signal is missing information.

Suggestion: Keep the animal within the 4 meter range of the receiver. If you exceed this range, the radio signal from the headstage will not be strong enough to maintain reliable signal monitoring of the animal. Also, be sure to keep the area under the RF receiver unit's antennas free from metallic objects, which will reduce signal range and introduce noise.

Problem: Not all channels are visible on the neural signal.

Suggestion: Make sure the headstage connection to the animal is secure.

Application Notes

- 1) The wireless headstage is a low-power device, it is critical that the RF receiver be carefully located for the system to operate. DO NOT place the receiver on the outside of a metal wire cage. Try to minimize the distance between the receiver and the wireless headstage. Please refer to the section in this document entitled [System Setup and Testing](#) for orientation suggestions.
- 2) If you do not intend to record from all of the available signal channels you must ground any unused channels at the electrode connector or EIB interface. Failure to do so can create artifact noise from the floating channels on the other signal channels.
- 3)

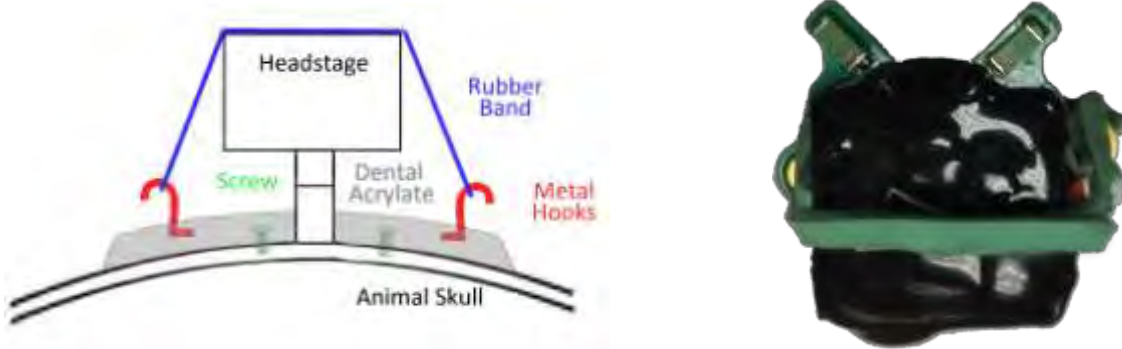

Contact Us

Triangle BioSystems International

2224 Page Rd. Suite 108

Durham, NC 27703

Phone: (919) 361-2663 • Fax: (919) 544-3061

www.trianglebiosystems.com

Need more help? You can reach TBSI customer support by phone at the number listed above (M-F Eastern US Time) or email us at support@trianglebiosystems.com. If you need replacement parts or accessories for your system or to learn the latest about available TBSI products visit our website, call or email us at sales@trianglebiosystems.com.

CAUTION

This product is not registered with the FDA and is not for clinical use on human or veterinary patients. It is intended for research use only.

